

UNCONTROLLED IF PRINTED; CONTROLLED DOCUMENT LOCATED IN IQMS DOCUMENT CONTROL

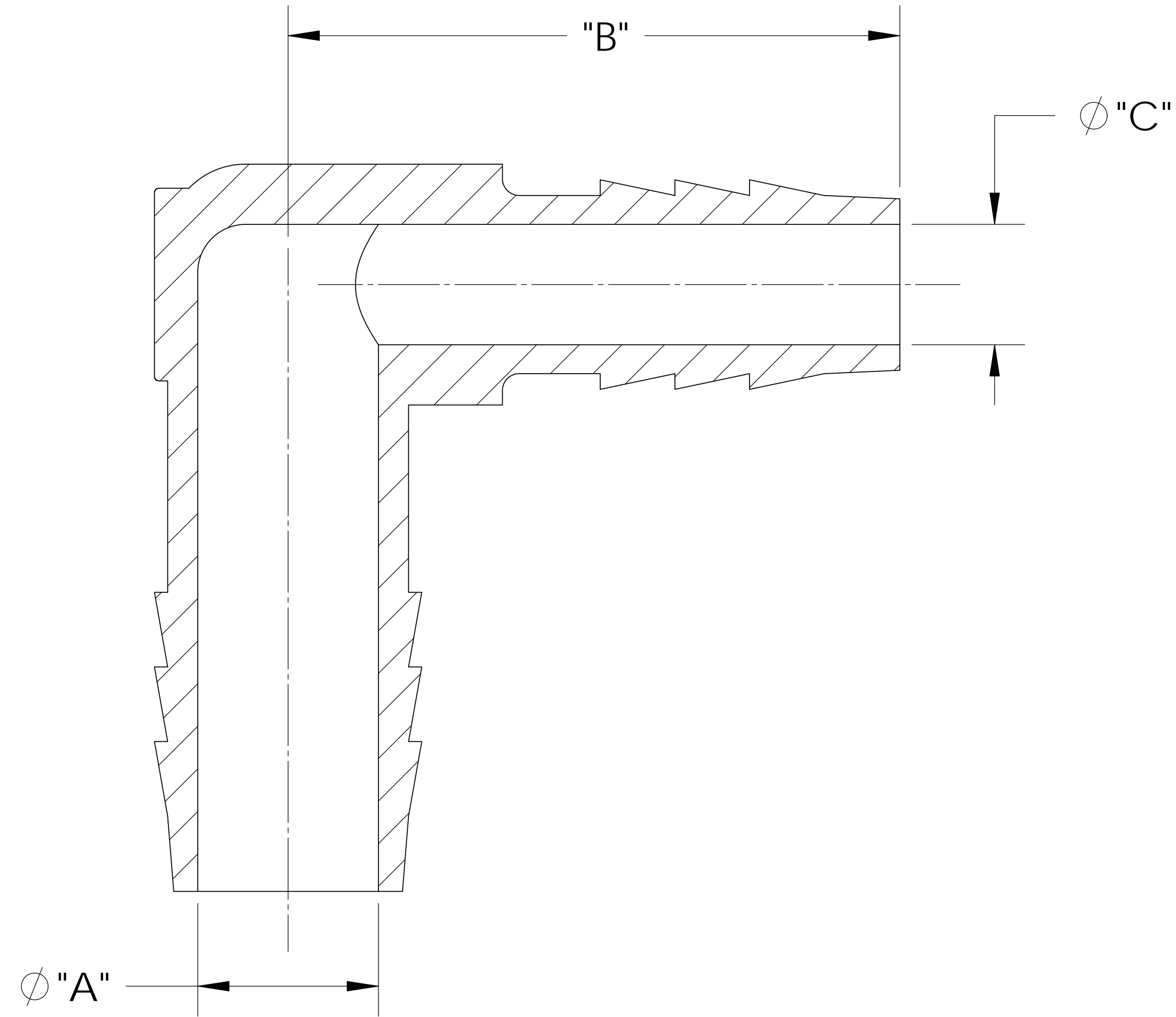

SECTION A-A

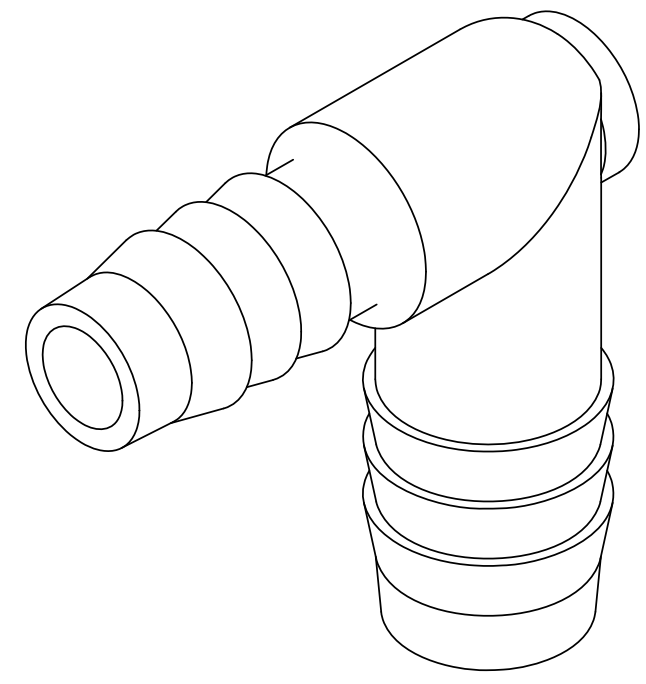
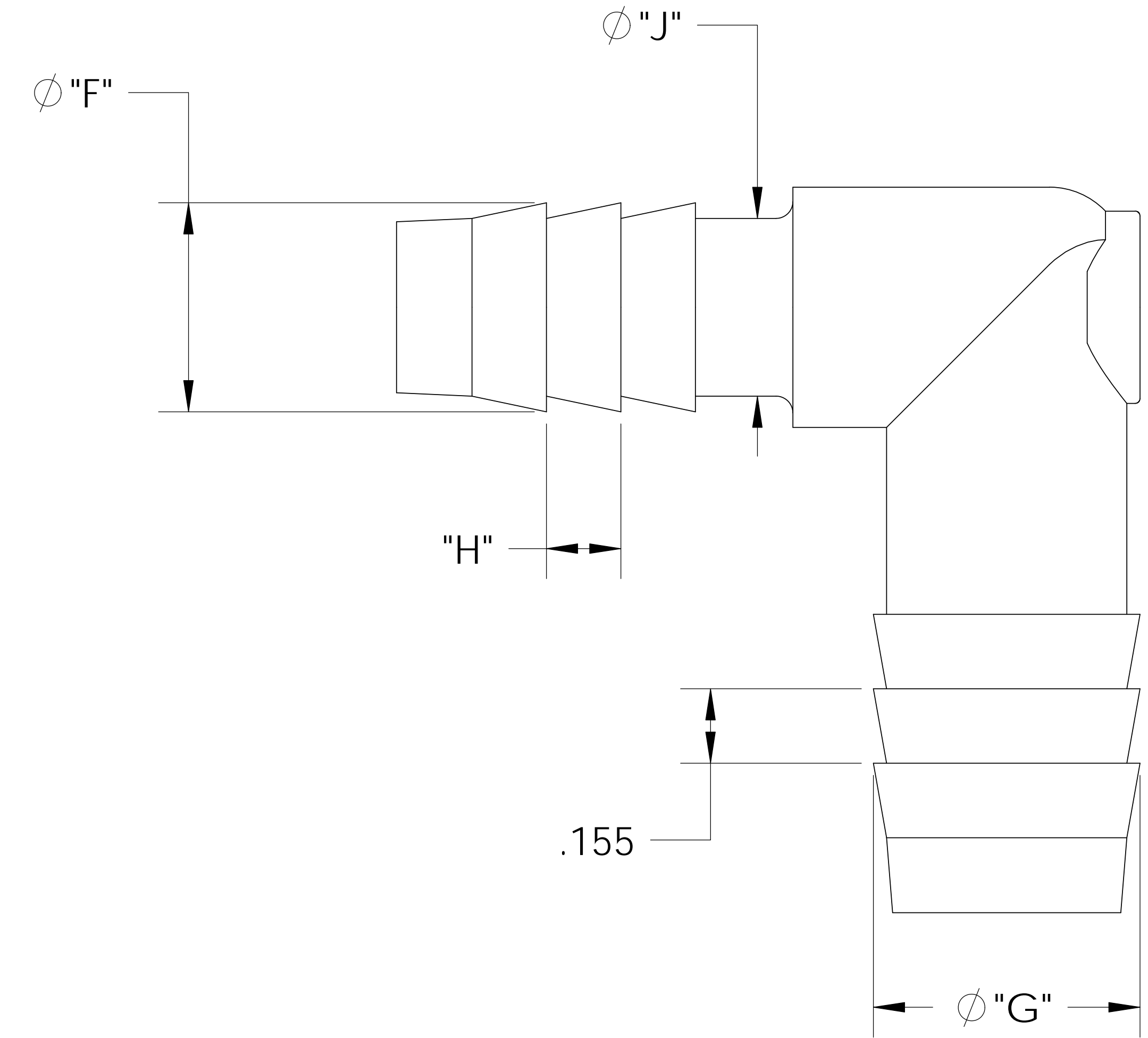
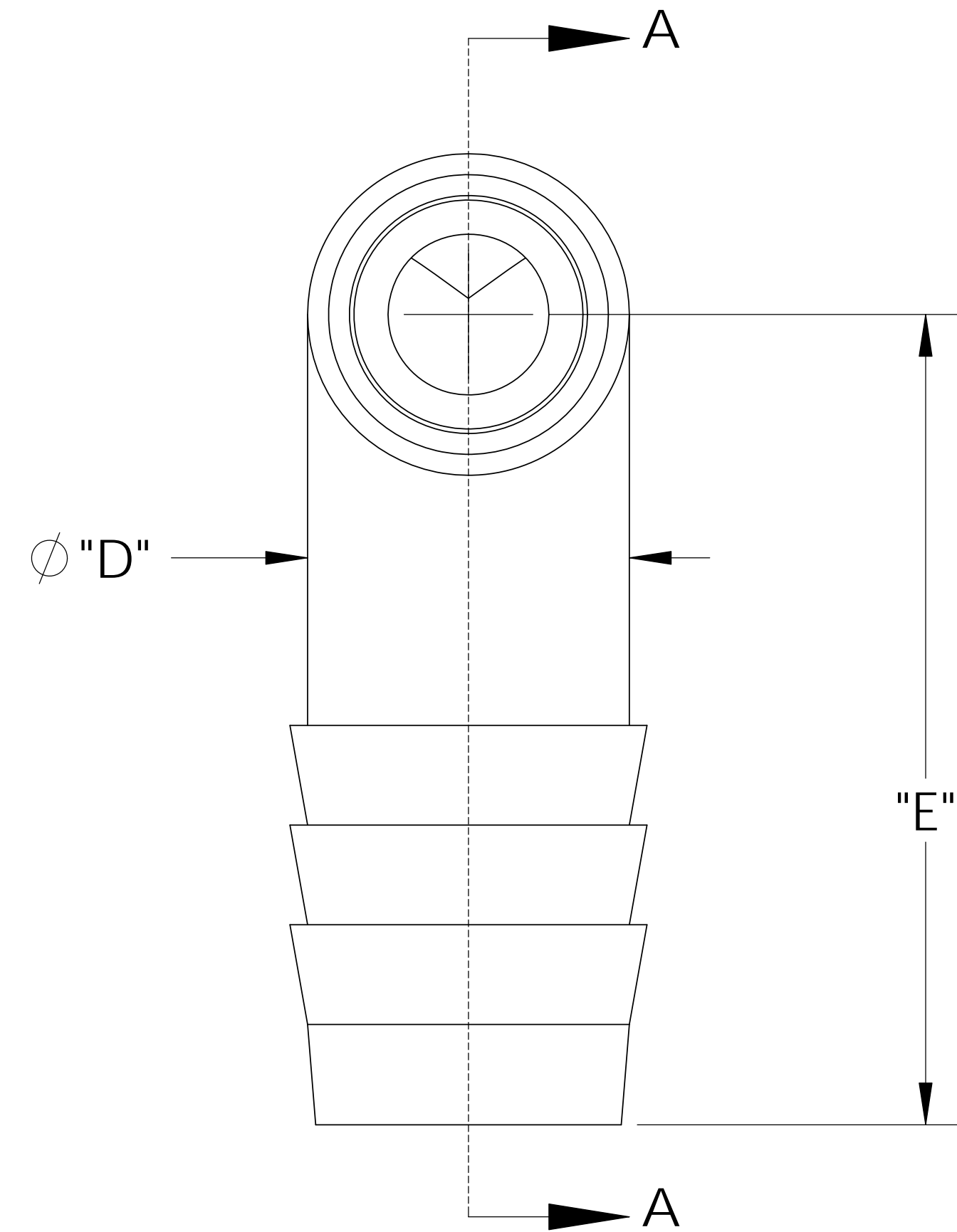

CATALOG NO.	DESCRIPTION	MATERIAL	DIM "A"	DIM "B"	DIM "C"	DIM "D"	DIM "E"	DIM "F"	DIM "G"	DIM "H"	DIM "J"
TE2086-T/PP	1/2 X 3/8 PP	POLYPROPYLENE	.370	1.27	.245	.495	1.25	.425	.545	.140	.365
TE2086-T/P	1/2 X 3/8 P	POLYETHYLENE	.365	1.22	.245	.505	1.22	.430	.550	.155	.370
TE2086-T/N	1/2 X 3/8 N	NYLON	.375	1.27	.250	.500	1.26	.435	.555	.155	.370

SHOWN

NOTES:

- 1) POLYPROPYLENE HAS COLOR OPTIONS:
 BLACK = TE2086-T/PPB
 NATURAL = TE2086-T/PPN

PROPRIETARY AND CONFIDENTIAL
 THE INFORMATION CONTAINED IN THIS DRAWING IS THE SOLE PROPERTY OF THOGUS PRODUCTS COMPANY. ANY REPRODUCTION IN PART OR AS A WHOLE WITHOUT THE WRITTEN PERMISSION OF THOGUS PRODUCTS COMPANY IS PROHIBITED.

REV	WRO#	DESCRIPTION
D	95.00035	CONVERTED TO 3D FORMAT

UNLESS OTHERWISE SPECIFIED:
 DIMENSIONS ARE IN INCHES
 TOLERANCES:
 ANGULAR: ±0.5°
 X.X = ± 0.1
 X.XX = ± 0.05
 X.XXX = ± 0.015
 REMOVE ALL SHARP EDGES AND BURRS
 BLEND ALL RADII TO 0.01IN
 INTERPRET GEOMETRIC TOLERANCING PER: ANSI Y 14.5 1994
 MATERIAL: PP, P, N
 FINISH: NA
 THIRD ANGLE PROJECTION:

NAME	DATE
DRAWN KDJ	10/25/10
CHECKED KDJ	10/25/10
ENG APPR.	XX/XX/XX
MFG APPR.	XX/XX/XX
Q.A.	XX/XX/XX

Thogus You think it, we can make it...
 33490 PIN OAK, AVON LAKE, OH 44012

TITLE: **BARB ELBOW, 1/2" X 3/8"**

SIZE B	DWG. NO. TE2086-T	REV E
SCALE: 2:1	MASS:	SHEET 1 OF 1

DO NOT SCALE DRAWING